

March 2015

Due Diligence Report

# Bishkek-Torugart Road Rehabilitation Project Project 3 (km 479 to 539)

Torugart Customs Post Approach Lanes.

Supplementary to Environment Impact Assessment report (March 2015).

**This document is prepared by the Ministry of Transport and Communications, Investment Projects Implementation Group, Kyrgyz Republic.**

## Contents

1.	INTRODUCTION .....	1
	PROJECT ENVIRONMENTAL PROGRESS	1
	LOCATION	1
	DESIGN AND CONSTRUCTION	2
	NEED FOR DUE DILIGENCE REPORT	2
	PHOTOGRAPHS OF THE SUBJECT AREA	2
	OWNERSHIP	2
2.	METHODOLOGY AND INFORMATION COLLECTION.....	3
3.	DESCRIPTION OF PROPOSED CHANGES TO THE PROJECT. ....	3
	OPTION 1	3
	REVIEW OF OPTION 1	4
	OPTION 2	5
	TOILET FACILITIES	6
4.	DESCRIPTION OF THE ENVIRONMENT AND ANTICIPATED IMPACTS .....	6
	PHYSICAL ENVIRONMENT	6
	BIOLOGICAL ENVIRONMENT BASELINE CONDITIONS	7
	SOCIO-ECONOMIC BASELINE CONDITIONS	8
5.	MANAGEMENT OF SOCIAL AND RESETTLEMENT IMPACTS .....	9
6.	CONSULTATION AND INFORMATION DISCLOSURE.....	10
7.	GRIEVANCE REDRESS MECHANISM.....	10
8.	CONCLUSIONS.....	11

### APPENDICES

APPENDIX 1 – SELECTED PHOTOGRAPHS OF PROJECT

APPENDIX 2 – PERSONS CONSULTED

### ABBREVIATIONS AND ACRONYMS

ADB	–	Asian Development Bank
AP		Affected persons
BNT	–	Bishkek-Naryn-Torugart
CAREC		Central Asia Regional Economic Cooperation
CRBC	–	China Road and Bridge Corporation
DDR	–	Due Diligence Report
EIA	–	Environmental Impact Assessment
GRG	–	Grievance Redress Group
IPIG	–	Investment Projects Implementation Group (former PIU)
LARP	–	Land Acquisition and Resettlement Plan
MOTC		Ministry of Transport and Communications
PRC		People’s Republic of China
RMU	–	Road Maintenance Unit
ROW	–	Right-of-way
TERA	–	TERA International Group

# 1. Introduction

## Project Environmental Progress

1. The Bishkek-Naryn-Torugart (BNT) project is part of the Central Asia Regional Economic Cooperation (CAREC) Transport Corridor 1 of the, linking the Kyrgyz Republic (KGZ) to People’s Republic of China (PRC). The BNT3 stretch from Km479 to Km539, runs through the Karatal-Japyryk State Nature Reserve which is protected by law and international conventions, up to the border with the PRC.

2. The environmental assessment of the project has progressed through several iterations. Throughout all versions the Project is designed to avoid, minimize and mitigate negative impacts on the environment during the construction and operation. In December 2009, an Environmental Impact Assessment (EIA) was prepared. In 2010 the EIA was updated to integrate some additional aspects and ensure compliance with the ADB Safeguard Policy Statement (SPS 2009); in particular concerns for natural and critical habitats. In 2012, the EIA was updated by international and national consultants. A group of scientists also conducted baseline surveys to underpin further ecological monitoring in the basin of the lake Chatyr-Kul proposed as part of an ecological response plan. In April 2014, the EIA was approved by the State Agency for Environmental Protection and Forestry (latrine design and permission from SAEPF. In 2015, the EIA was again updated to take account of amendments to the Borrow Pits Management Plan.

## Location

3. The Torugart Customs Post is shown in Figure 1 at Km532. This location performs as a temporary holding area for vehicles and travelers crossing to and from PRC.

**Figure 1 BNT3 Project location showing Torugart Customs Post**



## **Design and Construction**

4. The design of the BNT3 project originally envisaged introduction of a formal parking area on the left side near to the Torugart customs post (Km532) which would require relocation of privately owned caravans & containers that provide stop-over accommodation and canteen facilities for drivers and passengers transiting through the area. There are also rudimentary pit-latrines associated with the caravans.

5. The construction of BNT has progressed in the past two years (2013 & 2014) and the travel time from Naryn to Torugart has decreased significantly; especially after the completion of the BNT1 and BNT2 up to KM479. Subsequently Investment Projects Implementation Group (IPIG) the supervision consultants TERA International Group (TERA) and Contractor China Road and Bridge Corporation (CRBC) have been able to make more detailed observations on the pattern of driver stop-overs and other operations at the border post and the need for parking.

## **Need for Due Diligence Report**

6. In 2014 it was observed that the pattern of vehicle use near the border seemed to be for most drivers to queue and pass through the border post as soon as practicable, without stopover. Therefore the need for an extended parking area has reduced considerably. What is now needed is truck queueing facilities near the border post. In addition a toilet facility can also be provided to supplement the existing latrines used by the caravan occupants.

7. Therefore IPIG assisted by TERA and CRBC have progressed a modification of the road design for the 300m nearest the Torugart customs post (Km532) that would effectively replace the parking area with two queueing lanes on either side of the road from say Km531+700 to Km532+000 (approximately). This means there will be a change of footprint of the project in this limited area.

8. In order to capture unexpected impacts, that may result from changes of design, that may necessitate modifications to safeguards management arrangements, ADB may require the borrower to undertake due diligence. A Due Diligence Report (DDR) will be compiled to review the need for amendments to borrower's/client's social and environmental safeguards assessments and plans; resulting from the proposed changes and describing (if necessary) updating of environmental management or resettlement plans etc., to ensure that safeguard measures are in place and to avoid, wherever possible, and minimize, mitigate, and compensate for adverse social and environmental impacts.

9. This DDR presents the changes to the design proposed for the area the Torugart customs post (Km530) that can avoid relocation of privately owned caravans & containers and minimize and mitigate social and environmental impacts in the area. The need for any amendments to the environmental management plan and resettlement action plan are reviewed.

## **Photographs of the subject area**

10. Photographs of the road locality are presented in Appendix 1 and photograph locations are shown on Figure 1.

## **Ownership**

11. The project works for the existing section of the Project road (up to Km539) and the proposed queueing lanes lie within the ROW for the BNT3.

## 2. Methodology and Information Collection

12. The DDR has been prepared for BNT3 area Km531 as required under ADB Safeguards Policy Statement which requires due diligence to be carried out when a change of project design occurs at the implementation stage.

13. After a request from ADB in early 2015 the safeguards team in IPIG comprising specialists S. Keldibaeva, A. Abdygulov and TERA Deputy Resident Engineer I. Oserov visited the site, met local people and made photoreconnaissance in order to prepare this DDR and compiled the first draft of the report. The draft report was edited by Dr. David Green International Environmental Specialist, who has a detailed knowledge of the area and is very familiar with the terrain through work and intermittent site visits from November 2013 to October 2014.

14. The methodology has included the following tasks:

- (i) Collection and review of relevant reports such as detailed designs, feasibility study and other information provided by MOTC;
- (ii) Review of statistical reports prepared by At-Bashy department of the National Statistical Committee;
- (iii) Review of documents prepared by ADB, World Bank and other agencies;
- (iv) Consultation with relevant MOTC staff;
- (v) Consultations with Contractor;
- (vi) Consultations with residents in the project area;
- (vii) Field research along the entire road over March 12 to March 15 and
- (viii) Compiling the draft Due Diligence Report.

## 3. Description of Proposed Changes to the Project.

15. The BNT3 project is improving the existing road by upgrading it to an asphalt surfaced two lane carriageway with hard shoulders. The existing horizontal alignment is kept but the vertical profile is improved, crossing drains are replaced and numerous small culverts are replaced by larger box culverts that form new bridges (Figure 1). The Project is designed to remove bottlenecks in road transport, which might otherwise impede the expansion of trade, and facilitate regional economic cooperation.

16. The Project benefits are expected to filter through the surrounding region through economic development and increased access to markets and social services. Growth of trade cooperation between the Kyrgyz Republic and PRC is expected. The travel and transit time from Bishkek to Torugart will reduce from 3-4 days to less than 2 days. The improved road will reduce transport costs and contribute to the enhancement of the commercial and industrial development. The smooth operation of the border customs post is key to unlocking these benefits.

### Option 1

17. The Project as originally designed the concept provided for construction of a parking area at Km532 for vehicles stopping over at the Torugart Customs Post. This parking area included public toilets, waste collection facilities and a small area for light maintenance of vehicles. This option would have involved relocation of 11 caravan trailers that are furnished for accommodation and canteens which can be used by drivers. The caravans are located in a line about 20m-30m from the edge of the road (Figure 2, Option 1). However this option could not satisfy the primary objective of avoiding impacts as it required resettlement of the Caravans.

18. At an early stage IPIG assisted by TERA has developed a Resettlement Plan (RP) covering the requirements of ADB resettlement policy, compensation mechanisms to owners/lessees of these 11 caravan/trailers including a Grievance Redress Group mechanism. The RP has been agreed with ADB, and a Decree of the Government of the Kyrgyz Republic on compensation for lost income and possible damage to wagons during

their movement and idle standing was initiated. The GOK Decree was issued November 12, 2014.

**Figure 2 BNT3 Layout Options for Parking and Queueing near Torugart Customs Post**

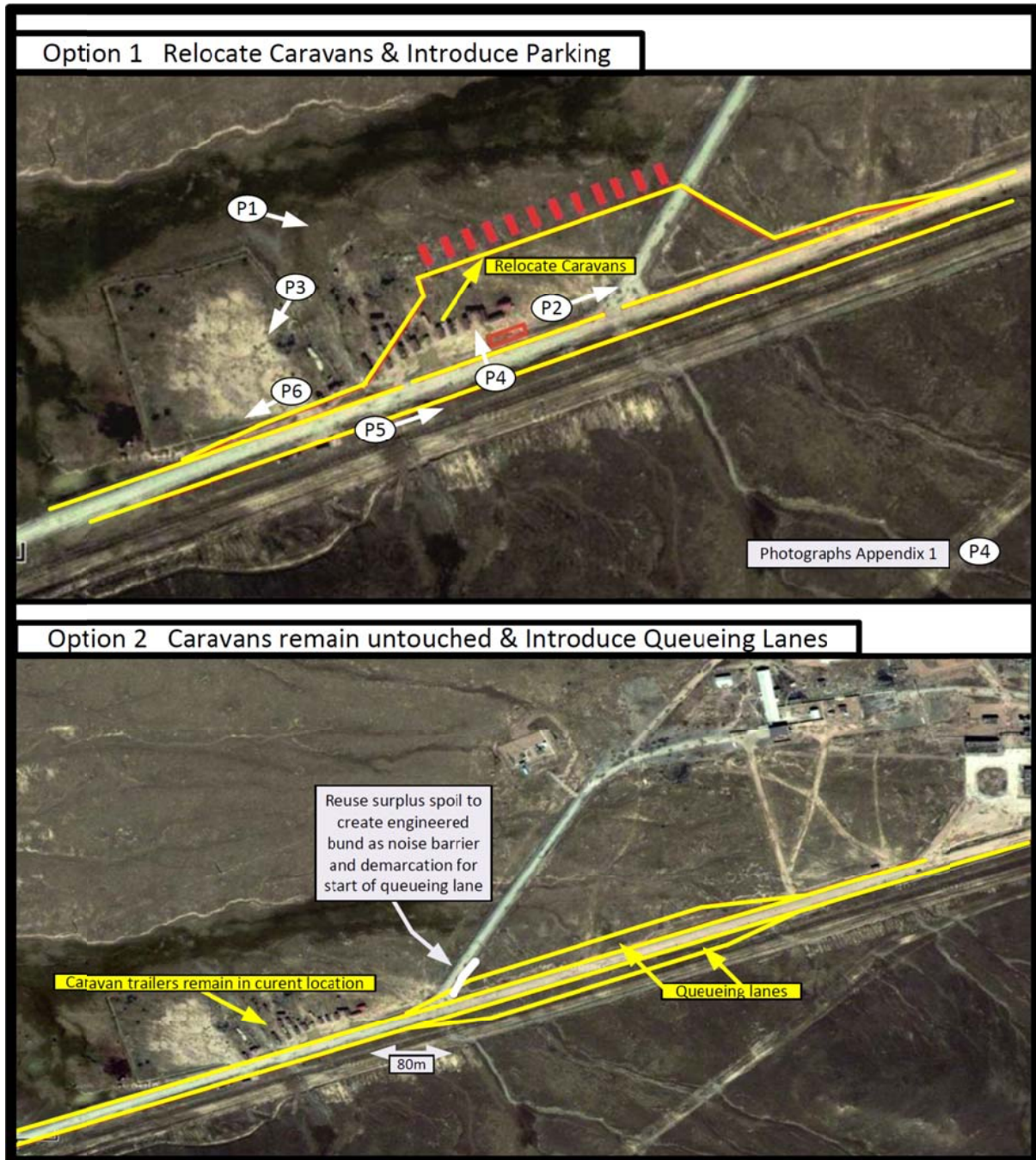

### Review of Option 1

19. However during the roll-out of the construction and detailed design of the eastern portion of the BNT3 Project, the access improved mainly due to the completion of BNT1 and BNT2. Based on observation, travel times from Bishkek were becoming reduced and the pattern of vehicle usage was changing. A number of issues emerged for the implementation of Option 1. These included (i) the reduction in the driving time from the border to At-Bashy (Km385) (ii) changing use of the border area from a stop-over area to a queueing zone (iii) the reduction in numbers of vehicles stopping at the caravans (iv) withdrawal of some caravan owners from the area due to lack of patronage (v) planned improvements to the Torugart Customs Post. The emergence of these issues seemed to indicate that a review of the need to create a large parking area and therefore the need for relocation of the caravans.

20. Therefore MOTC has revised the planned construction of a standard parking area original designed to relieve the road of long queues of trucks. There are also other reasons a change of approach is required.

21. If drivers were to leave the road and park up for a period they would lose their place in the queue and therefore their priority of entry to the Torugart Customs Post (the first truck arriving enters first). Anecdotal evidence suggests that if the order of entry is violated, while in the queue, clashes and quarrels among drivers will occur and sometimes extreme violence will erupt. One incident, due to queue violation, has escalated to the use of firearms.

22. The imminent entry of the Kyrgyz Republic to the Customs Union (CU) planned for May 2015 makes it incumbent on Kyrgyz Republic to improve and develop the infrastructure of the customs terminal itself to the satisfaction of the CU. Thus the dilapidated caravans will be in competition with any new facilities in the customs terminal.

23. By the time that all of BNT3 is completed and all the road to Naryn is improved the drivers are presumed not to stop for a long time at the remote border area. Given the reduced travel time to the village of At-Bashy, drivers will be able to find better facilities for rest and food there. In view of this, the MOTC together with the Customs Service of the Kyrgyz Republic has jointly reviewed the provisions for the Torugart Customs Post.

## **Option 2**

24. The joint review has concluded that alternative provisions are required and that additional parking lanes are a better option for vehicles traveling from Kyrgyzstan to China at km 531.

25. Therefore the Contractor CRBC prepared a design change, providing for additional 3.5m wide lanes over 300m just west of the Torugart Customs Post for queueing of vehicles entering China from Kyrgyzstan. Along the distance of additional lanes there is no any social facility just an empty and tenantless area. All these additional lanes area is within ROW and there is no need to any land acquisition (road is category III, width of ROW is 28m).

26. The conceptual design for the parking lanes is shown in Figure 2, Option 2. The new queueing lanes will abut Torugart Customs Post and the Customs Service, in turn, will equip the terminal and build a platform for vehicles entering in Kyrgyz Republic from China. At the entrance to the Kyrgyz Republic vehicles carrying freight will also pass over a weighbridge control point mounted within the improved customs terminal.

27. This change to the layout at the design road just after Km531, can avoid direct impact on the caravan-trailers, located on the left side, avoiding their relocation. In addition as the caravan-trailer area remains unaltered by the project there will be no resettlement impacts and the caravan-trailer operators can pursue their livelihood unhindered in the current location. The impacts during construction such as dust and noise are mitigated by the measures specified in the SEMP; which requires the Contractor to implement the SEMP and make timely mitigation measures such as spraying water as dust suppression. The impacts will be temporary and no greater than expected with the planned construction of the road.

28. Additional measures such as installation of a noise barrier has also been considered. One option would be to collect spoil material from construction activities and form an engineered bund (say 1.5m high as shown in Figure 2, Option 2) to act as a noise barrier. The bund can be contoured and compacted to reduce the wind shear on the surface and the dust generation can therefore be reduced. Based on observation at the site and professional experience the separation distance is >80m and any dust generated after construction should not be noticeable above the existing background dust levels. A compacted bund can be built with say 45 degree side slopes for a stable angle of repose and the top can be rounded off to reduce wind shear. To achieve a 1.5m height the base would be about 4m to 5m wide. The surface can be compacted with surplus stockpiled topsoil. The contractor will construct the noise barrier.

29. In addition to the noise attenuation the engineered bund would also provide
- (i) segregation from the caravan trailers at the west end of the queueing lanes;
  - (ii) visual shielding, landscaping and a neater finish to the end of the queueing lane; and
  - (iii) support to traffic management by marking the start of the queueing lane area.

### **Toilet Facilities**

30. During consultations carried out earlier by IPIG to support the EIA it was discussed and proposed that some toilets should be included near the border, somewhere near the caravan-trailers. Some owners & tenants have stopped commercial activity recently due to the lack of demand and have returned to their permanent residences. During consultations carried out to support the DDR IPIG safeguard staff met again with some of the few remaining caravan-trailer owners and tenants and explained to them the new road section design. Trailers owners and tenants requested that IPIG arrange for the installation of a two room latrine. Thus the provision of the latrine toilet is carried forward in Option 2. The permission for the latrine was already obtained from State Agency for Environmental Protection and Forestry (latrine design and permission from SAEPF to construct are enclosed as Attachment 2). The location of the latrine will be determined in line with the requirements of the SAEPF permit. IPIG have confirmed that after construction the toilets will be commissioned and cleaned by the construction contractor for the duration of the Contract. IPIG have indicated that the necessary arrangements for the toilets to be kept in an operationally sustainable condition and cleaned will be made with the staff from the nearest Road Maintenance Unit.

## **4. Description of the Environment and Anticipated Impacts**

### **Physical Environment**

31. The road section is located in a valley surrounded by mountains on the perimeter, the altitude is 3578-3615m above sea level (masl). Wetlands and pastureland with sparse vegetation dominate in the area. There are no permanent settlements and domestic buildings in the valley. There is one army post and the Torugart Customs Post. In summer local herdsmen bring thousands of cattle and goats into the valley to graze on Government sanctioned pastureland.

32. The Project road is located about 2km from the Ramsar site (about 3km from Chatyr-Kul at its nearest point (Figure 1). The Project area is characterized by numerous ephemeral streams and a few small lakes and ponds that run towards Chatyr-Kul. The buffer distance to the Lake generally allows for construction work to proceed with minimal impact on the most sensitive areas. There will be no impact on the lake during the construction of the queueing lanes.

33. **Topography:** The Project area is located in the southwest of the Naryn oblast. The main orographic characteristics of the Project area:

- At-Bashy Ridge is located in the southern part of the Inner Tien Shan range. Its average height is 4300m above sea level (masl). The BNT road runs parallel to the ridge (for 100 km) crosses it at the western end.
- Torugart-Too mountain range serves as the border between Kyrgyzstan and China. The length of the ridge is 64 km long.
- Valley Arpa is a high mountain valley located to the west. The length of the valley is 60 km, and the altitude is 2700-3600 masl.
- Chatyr-Kul Valley is a high mountain basin, located between the ridges Torugart-Too and At-Bashy. The length of the valley is 48 km and the width is 18 km. The Chatyr-Kul lake occupies most of the lowland of the valley.

34. **Climate** conditions along the Project road are diverse in its various parts, due to the large difference in the altitude. Around the lake the climate of the area is harsh with snowy



winter. Summer is short and cool. The warmest months are July and August, when the air warms-up to 15-18°C, but at night there are still frosts. The average annual temperature here is 5.6°C. In winter the temperature drops to -50°C and the maximum summer temperature rises to +24°C. Snow may fall even in summer. The maximum monthly temperature at Chatyr-Kul area is less than 10°C in July and the minimum reaches -20 °C in January. The average temperature is above 0°C only from May to September. Total annual precipitation is less than 300mm, and the maximum recorded thickness of snow cover is 400mm.

35. An important element of the Project area climate is the wind, mainly from the west. The speed being 1.5 - 3.9 m/s. High summer daytime temperatures combined with strong wind cause a rapid evaporation of soil moisture, which further limits growth of pastures which are overgrazed.

36. **Air quality** is generally acceptable with all parameters measured in 2014 within the maximum acceptable limits set by Government. The road was in bad condition but as the asphalt is being laid section by section dust is reduced and visibility is improved. Dust still arises on the unsealed sections but this will reduce progressively in 2015. The existing road around the Torugart Customs Post and caravans is in poor condition causing dust to arise when vehicles pass over unsealed sections. The new road will be properly sealed and dust will be controlled over the road and the queueing lanes. The nearest point of the queue lanes is about 80m from the caravans and much further from the Torugart Customs Post which will allow ample buffer distance for the dispersion of gaseous emissions from queueing vehicles.

37. **Noise** from vehicles is not a concern in the areas around the Torugart Customs Post at present as traffic is confined to occasional vehicles. The nearest point of the queue lanes is about 80m from the caravans. Noise mitigation measures are included in the environmental management plan to ensure construction and operational vibration does not escalate to unacceptable levels. Noise will increase gradually but not to unacceptable levels.

38. **Vibration** from vehicles is detectable where the vehicle currently queue in front of the caravans but this will reduce in future as the queueing lanes will be more than 80m from the nearest caravan. Vibration will increase gradually as traffic increases but the additional base course depth on the road should have a beneficial effect to dampen vibration. Mitigation measures are included in the environmental management plan to ensure construction and operational vibration does not escalate to unacceptable levels.

39. **Soil contamination** is not a concern in the areas around the Project road at present and soil contamination should not be a problem in construction or operation and mitigation measures will be included in the environmental management plan to control any residual effects.

40. **Solid waste** disposal in construction or operation will be controlled by mitigation measures included in the environmental management plan.

41. **Water** Socio-economic surveys of the Project area show that the majority of people that use the Project area in the valley take the underground water from springs and wells for drinking.

42. The small dry gullies that cross the alignment occasionally entrap rain water and discharge towards the lake; but often dry up soon after the snows have melted.

### **Biological Environment Baseline Conditions**

43. The ground cover on the valley neat the road generally comprises bare surfaces and flat grassed areas. There are no trees. Prolonged exposure of the bare surface to rainwater causes a compacted surface.

44. The key environmental feature of the Project is the protected area and Ramsar Site around Chatyr-Kul lake (Figure 1). It is considered as critical habitat according to the Convention on Wetlands of International Importance (Ramsar Convention). In accordance

with the ADB SPS 2009 “the project should develop mitigating measures to ensure absence of net loss of the biodiversity. This requirement is being achieved through the provisions of the Ecological Response Plan which is part of the EIA.

45. The human impact on the vegetation is pronounced in the area especially near the roads due to cattle and goat grazing but the biodiversity of the Ramsar site remains high in 2015 due to the implementation of the environmental management plan (as monitored throughout the 2014 construction season.

46. The implementation of the changes will not cause any additional environmental impacts. The area of the road for queueing will be widened for about 300m but the area for parking will be correspondingly reduced. There will not be any cross border environmental impacts. There will not be any global impacts or impacts on the protected areas or important bird areas due to the separation distance to the Ramsar Site.

### **Socio-Economic Baseline Conditions**

47. There are no permanent domestic settlements along BNT3 except the periodic residents at the checkpoints at Km479 and the Torugart Customs Post at km 531. These persons are the Customs Post officers and the border security forces personnel that come to site for a few / several months at a time. Customs and border guards are assigned to the checkpoints and live at the hostel at Km423 (right side). They live in that accommodation that is located on the right side about 300m back from the bend at Km523. This location is one of the noise and air quality monitoring stations.

48. **Livelihoods:** The shepherds’ families that visit the valley in the summer raise livestock and are allowed to graze cattle near the lake Chatyr-Kul from April to October. The shepherds families do not stay in the right of way. They come by truck and unload the prefabricated Yurt (traditional hut) and when it is constructed live in that for the summer months (200m-300m away from the road - not in the ROW). The locations can be anywhere the shepherds can find some grass to feed the cattle and goats on. The Yurt is taken down after the grazing is over and they move back to their winter base out of the valley and take the goats and cattle with them. Project construction does not affect their livelihood as there is no good grass in the right of way. This area close to the road is frequently a barren area and generally sheep grazing takes place quite far from road; the sheep flocks are relocated deeper into the Arpa valley as soon as grass gets poor near the site. Prior to project implementation and during project no accident caused by cattle has been registered. Drivers appear to be quite cautious of the cattle and goats. As soon as road marking works start the specific road signs will be installed warning drivers about possibility of cattle appearance on road.

49. Socio-economic survey showed poor quality of life of these families, and they expect the road rehabilitation will improve the seasonal access for transport of their property (survey data are given in EIA Annex 2 dated 11/02/15). The shepherds’ families generally raise temporary accommodation 400-500 meters from the existing road, so the traffic does not affect them directly. Stray cattle may interfere with vehicles if they cross the road.

50. The Torugart Customs Post at Km 531 is dilapidated and decaying due to lack of maintenance. The old telecommunication system is more or less technologically obsolete. There is no proper drinking water supply system, the sanitation facilities and solid waste collection and disposal are in poor condition. Drinking water is obtained from the nearby Narzyn Spring.

51. There are 2 road maintenance bases (DEP) in the area of the Lake Chatyr-Kul. One DEP is near Tuz-Bel pass. The other is near the Torugart Customs Post. These facilities do not meet the needs in terms of modern transport loads, but continue to operate. However, they have enough space for the pre-positioning of emergency equipment and materials needed in cases of traffic accidents.

52. As described earlier, just to the west of Torugart Customs Post there are the caravan-trailers on the left side (Km 531, Appendix 1). These wagons are privately owned,

reconfigured into rudimentary accommodation and canteens and serve drivers and passengers transiting through the area. According to available information, the drivers that used to stop for 1-2 days before crossing the border, are now transiting the area more rapidly.

## 5. Management of Social and Resettlement Impacts

53. The resettlement action plan has made provisions to compensate for land acquisition and loss of property, material goods livelihood during the implementation of the Project. The methodologies are described in the following section.

54. The Project follows the ADB's Safeguards Policy Statement (2009) and Operations Manual (OM) Section F1/BP (2010), the Constitution of the Kyrgyz Republic, the Land Code (LC) and the Civil Code (CC) of the Kyrgyz Republic.

55. The Constitution of the Kyrgyz Republic was adopted in June 2010. It is the main legal instrument to ensure the rights of citizens. Article 12 stipulates that "The diversity of forms of ownership is recognized in the Kyrgyz Republic and equal legal protection of private, state, municipal and other forms of property is guaranteed. Seizure of property for public purposes, as defined in the law, may be executed by the court's decision in order to ensure fair and prior compensation for the value of this property and other damages caused as a result of alienation. The land may also be in private, municipal and other forms of property, except for pasture, which cannot be privately owned."

56. Compensation for land acquisition and other impacts of investment projects are regulated by other legislative acts, including the Land Code (LC) and the Civil Code (CC).

57. Land Code (1999) is the main legal instrument for the land acquisition. It has been updated several times; the latest amendments were introduced in 2009. Paragraphs 62 and 66 of the LC define the mechanisms for finalization and voluntary transfer of land on the various grounds.

58. Paragraph 49 of the Land Code states the rights of landowners: the owners should receive full compensation for the loss in the cases stipulated by the Kyrgyz legislation. Item 68 of the LC appeals to ensure that private owners have received financial compensation from the loss of land, or provided with the other land, equal to the total market value. If agreement on compensation cannot be achieved, the responsible agency may declare the land acquisition and compensate the landowner or land user in accordance with the court decision within two months (Item 68, Article 1).

59. The following basic principles of ADB's Policy on Involuntary Resettlement have been used as a guide the Project and in compiling the resettlement plan:

- (i) Involuntary resettlement should be avoided or minimize by exploring all viable project options;
- (ii) Identification of affected persons and compensation for lost property and income;
- (iii) Assistance in resettlement and restoring the living standards to the level without the project;
- (iv) The affected people should be fully informed and closely consulted on resettlement and compensation options;
- (v) The absence of formal legal title should not be a bar to compensation or assistance in rehabilitation of livelihood;
- (vi) Pay special attention to particularly poor and vulnerable groups.

60. However with the adoption of Option 2 it appears that resettlement can be avoided altogether and by avoiding the associated impacts in line with ADB policy, resettlement is not necessary and there is no need for compensation. Hereby the further governmental

procedures will be taken concerning LARP approval decree issued last year and still being in force.

## 6. Consultation and Information Disclosure

61. The objectives of the stakeholder consultation process is to disseminate information on the project and its expected impact, long-term as well as short-term, among primary and secondary stakeholders and to gather information on relevant issues so that the feedback received can be used to address these issues at early stages of project design. Another important objective is to determine the extent of the concerns amongst the community, to address these in the project implementation and to suggest appropriate mitigation measures. The feedback received has been used to address these issues at early stages of project design.

62. Information disclosure is being undertaken as per the requirements of SPS and Government requirements. Several sessions of consultation meetings have been held at the Torugart area and with local officials. Since 2013 and further one to one discussions have been undertaken recently. The stakeholders included local affected persons, local authorities, national authorities and all were generally in favour of the project

63. IPIG Safeguard staff met again with the few trailer owners/tenants remaining. Some present in 2013 have now returned to home base and stopped their activity due to the lack of customer. IPIG have explained to them the new road section design.

64. Trailers owners/tenants have requested to make access to their trailers since new road will be higher and for convenient approach they need access. Also they requested to install one two room latrine. The permission for latrine was already obtained from SAEPF (latrine outline and permission from SAEPF enclosed as Appendix 2). The exact location of the latrine will be determined later. It was noted that from end February to end April there is a strong wind, snowstorm and snow goes to trailers side forming snowdrifts which also cause a difficulties in approaching trailers. Therefore, it was recommended to make periodic snow cleanup by local Road Maintenance Unit.

### 1. Table 1 List of persons consulted

#	Name	Position
1.	Usubakunov S.M.	Trailer's tenant
2.	Abylov Z.M.	Trailer's tenant
3.	Tentimishova M.	Trailer's tenant
4.	Jusupova O.	Trailer's tenant
5.	Tursunbaev R.	Head of Torugart police office
6.	Bayaliev B.	Trailer's tenant
7.	Akbaeva N.	Medical assistant
8.	Asanova S.	Trailer's tenant
9.	Omurakunov U.	Head of East customs
10.	Abas uulu Kubanychbek	Head of Torugart post

## 7. Grievance Redress Mechanism

65. Earlier in the project a Grievance Redress Group (GRG) was established according to ADB's Safeguards Policy Statement. The GRG member in charge shall visit the site regularly to meet the local residents, and the local residents can contact him/her by mobile communication in case of any appeals, requests or claims. No claims have been registered so far, as no works were done at the site.

66. Consultations will continue throughout construction phase as per the Project's communications plan. Records including reports on environmental and social complaints and grievances will be kept in a simple database in the IPIG office.

## 8. Conclusions

67. The road is predominantly an existing piece of infrastructure that does not create any impacts not already anticipated. The impact on the environment during the construction at the site will not be significant and will have temporary and reversible nature.

68. The EMP (EIA dated 11.02.15) remains effective and has been efficiently monitored in 2014 and will continue to be monitored until the Project is completed. The two streams of environmental management namely: (i) control over the contamination sources, and (ii) protection of receptors [biodiversity] will remain in place for the duration of the project. The accepted EMP and mitigation measures should be effective to control all expected impacts but adjustments will be made if any unexpected impacts occur during the construction period to minimize the impact on the environment.

69. The proposed design (Option 2) involves the construction of additional queueing lanes for vehicles traveling out of the Kyrgyz Republic. This would appear to offer a viable alternative to the previous Option 1. Option 2 is acceptable environmentally and offers some other advantages both financial and social. Abandonment of the parking area will avoid the movement of the caravan-trailers and thus, the resettlement is no longer required. The proposals are socially acceptable to the local tenants. The cost of resettlement and the large lorry park area is avoided. The project will provide improved safety by segregating queueing vehicles from the caravan-trailers by 80m and help to reduce risk of accidents. Idling vehicles are moved to queue away from the trailers.

70. During construction, the Contractor will take all measures to mitigate the adverse effects (such as noise and dust) and the Consultant in turn will run strict monitoring of the Contractor's activity and timely undertaking of mitigation measures in line with the accepted EMP. IPIG safeguard specialists will periodically visit the site during the construction active phase of works to monitor the environmental impacts and check on the implementation of the EMP.

71. The project will not create any additional impacts on cultural or heritage sites and neither does it pass through densely populated areas or an area subject to heavy development. The proposed project will not create conflicts with natural resource allocation.

72. The construction impacts should be very predictable and manageable and with appropriate mitigation few residual impacts are likely. Implementation of appropriate measures during the design, construction, and operation phases will minimize negative impacts to acceptable levels. To ensure that these mitigation measures are implemented and negative impacts avoided, the measures have already been included in the contract specification. Environmental monitoring of the project will continue to be undertaken regularly through the construction to ensure that the measures are being implemented properly.

Hereby based on the above-stated the result of design change (Option 2) is **no resettlement** considering the following: a) no parking area construction means no trailers movement, b) additional lanes does not require any land acquisition being within ROW and c) the area of additional lanes is empty and tenantless.

Appendix 1-Selected Photographs



Photograph 1  
View to Torugart Customs Post, caravan-trailers & queueing trucks from north-west (looking south-east)



Photograph 4  
View of dilapidated caravan-trailers from south (looking north-)



Photograph 2  
View to Torugart Customs Post, queueing trucks on north side (from west looking east).



Photograph 5  
View to Torugart Customs Post, queueing trucks on south side (from west looking east).



Photograph 3  
View south west to trucks approaching queue at Torugart Customs Post. Animal coral foreground.



Photograph 6

View to Torugart Customs Post, caravan-trailers & queueing trucks from north-west (looking south-east)

Appendix 2 Permission to construct latrine and plan

<p>КЫРГЫЗ РЕСПУБЛИКАСЫНЫН МӨ КАРАШТУУ КУРЧАП ОРГАН ЧӨЙРӨНУ КОРГОО ЖАНА ТОКОЙ ЧАРБАСЫ МАМЛЕКЕТТИК АГЕНТТИГИ</p>		<p>ГОСУДАРСТВЕННОЕ АГЕНТСТВО ОХРАНЫ ОКРУЖАЮЩЕЙ СРЕДЫ И ЛЕСНОГО ХОЗЯЙСТВА ПРИ ПРАВИТЕЛЬСТВЕ КЫРГЫЗСКОЙ РЕСПУБЛИКИ</p>
<p>720001, Бишкек ш. Токтогул көч. 228 тел. (996-312) 352727, факс: 353102, 353094 e-mail: <a href="mailto:nature_kg@mail.ru">nature_kg@mail.ru</a>, <a href="mailto:ecokg@aknet.kg">ecokg@aknet.kg</a>, <a href="http://www.nature.kg">www.nature.kg</a> Биринчи май КРБ, ЖИН: 02001200610051 э/б: 129052238181004, БИК: 129052, Банк: Бишкек Филиалы ААК «РСК-Банк» ОКПО: 23994204 0253101 2</p>		<p>720001, г. Бишкек, ул. Токтогула, 228 тел. (996-312) 352727, факс: 353102, 353094 e-mail: <a href="mailto:nature_kg@mail.ru">nature_kg@mail.ru</a>, <a href="mailto:ecokg@aknet.kg">ecokg@aknet.kg</a>, <a href="http://www.nature.kg">www.nature.kg</a> Первомайский РОК, ИНН: 02001200610051 р/с: 129052238181004, БИК: 129052 Банк: Бишкекский Филиал ОАО «РСК-Банк» ОКПО: 23994204 0253101 2</p>
<p>16.06.2014-ж. № 04-01-28/1343</p>		
<p>№ _____</p>		
	<p>Министерство транспорта и коммуникаций Кыргызской Республики  Нарыньское ТУ ГАООСЛХ</p>	
<p>На Ваш исх. № 14-3/3310 от 23.05.2014г. Государственное агентство охраны окружающей среды и лесного хозяйства при Правительстве Кыргызской Республики (ГАООСЛХ), рассмотрев Ваше письмо исх. № 14-3/3310 от 23.05.2014г. о планируемой строительстве парковочной зоны с необходимой инфраструктурой, для обеспечения дорожной безопасности и уменьшения скопления автомашин вдоль автодороги перед таможенным постом «Торугарт» и заключение по отводу земельного участка выданное Нарыньским территориальным управлением ГАООСЛХ № 108-в от 12.06.2014года, не возражает в планировании строительства общественного туалета на 530 км автодороги Бишкек-Нарынь-Торугарт. При этом необходимо: - представить соответствующую проектную документацию по планируемым объектам парковочной зоны, в соответствии законодательством Кыргызской Республики, на государственную экологическую экспертизу в Нарыньское территориальное управления ГАООСЛХ до начала строительства.</p>		
<p>Заместитель директора</p>		<p>А. Рустамов</p>
<p>Жумабеков Рыенков Сарыбаев тел.: 900814</p>		
<p>что .</p>	<p>б. № 248.</p>	<p>Кыргыз Республикасынын Транспорт жана Коммуникация Министрлиги 03159 Кириш № 1631 " 17 " 06 2014 г.</p>



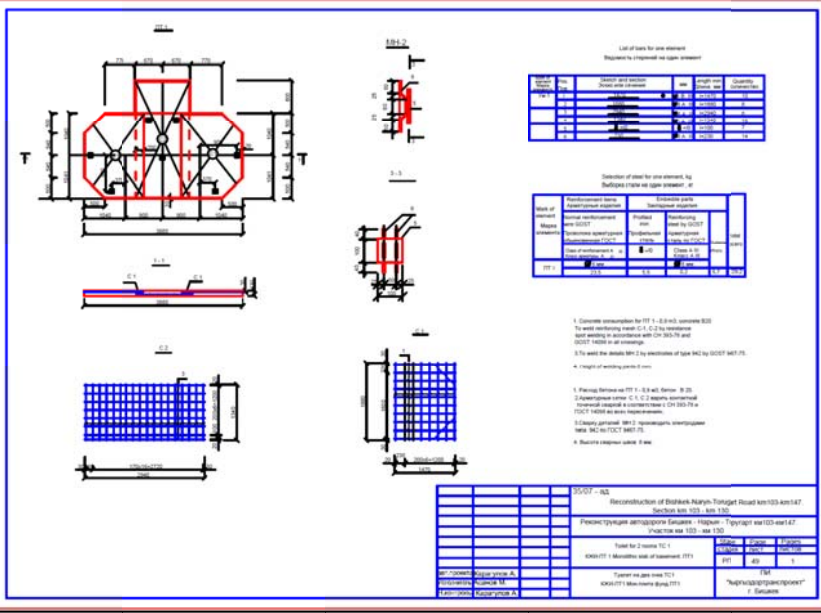
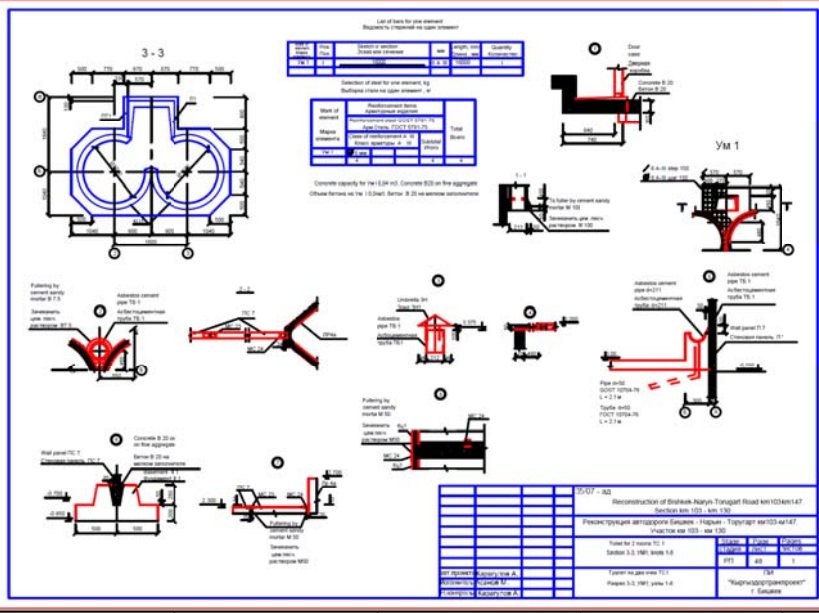
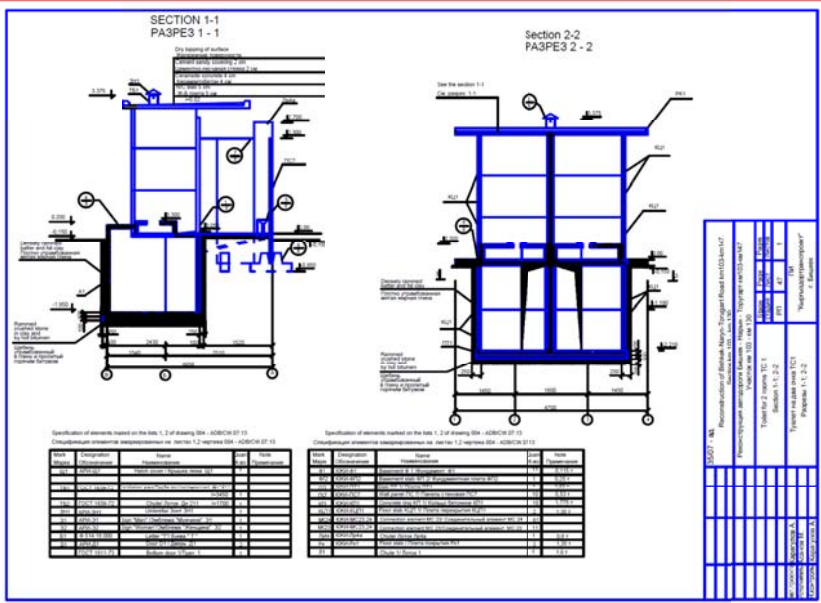
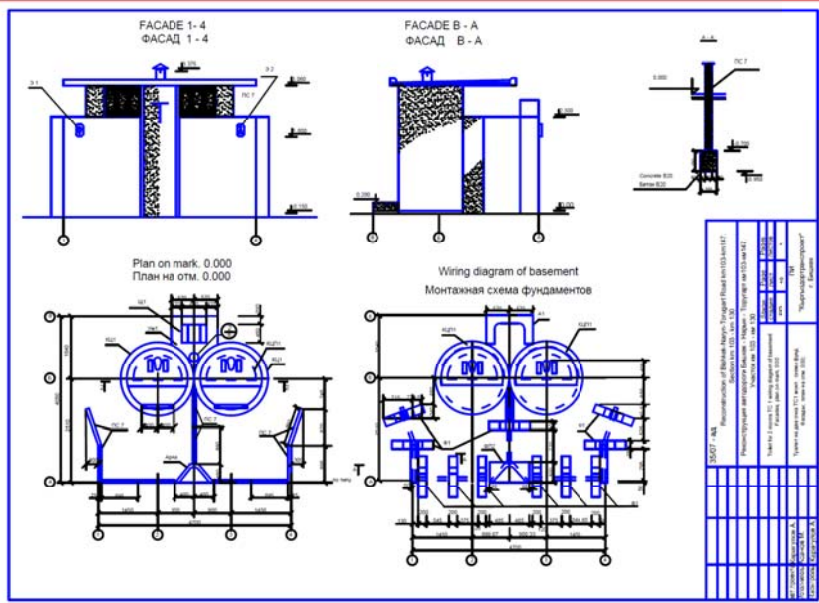

**Нарынское территориальное управление охраны окружающей среды**

**ЗАКЛЮЧЕНИЕ № 108-в**  
По отводу земельного участка  
«12» 06 2014 года.

1. Наименование объекта, для которого отводится участок, его ведомственная принадлежность: Строительство санитарного узла - общественной туалета
2. Место нахождения участка: ул. Торугарт от Бишкекской к-ны
3. Наименование документов, на основании которых дано настоящее заключение: Объяснения должностного лица Нарынского и Коммунистического к-нов.
4. Производился ли осмотр участка в натуре: да, 06.01.2014 г. при Кардыбе Ата.  
комиссией в составе: Исходичи, Камыш.
5. Характеристика земельного участка (территории) с/узел в общественной туалета
  - а) размеры (площадь) \_\_\_\_\_
  - б) рельеф: сплошной
  - в) характеристика и вид грунта: засеянный
  - г) высота стояния грунтовых вод: более 5 м.
  - д) наличие заболоченности \_\_\_\_\_
  - е) наличие и количество зеленых насаждений \_\_\_\_\_
  - ж) расстояние от озера, реки, канала \_\_\_\_\_
6. Использование участка (территории) в прошлом: расчистка участка
7. Размещение участка по отношению к окружающей территории, имеющимся строениям: на территории нежилых зданий, слева фанера с/уз.
8. Господствующее направление ветров: Золариты
9. Характеристика возможных влияний указанного объекта строительства на окружающую среду и экологическое условие жизни населения (не влияет при строгом соблюдении норм и правил природоохранного законодательства)  
указанного документа
10. Источники водоснабжения, возможность организации зоны санитарной охраны \_\_\_\_\_
11. Возможность канализации объекта \_\_\_\_\_
12. Место спуска сточных вод (соответствие требованиям) \_\_\_\_\_
13. Возможность теплоснабжения объекта \_\_\_\_\_
14. Проведена экологическая экспертиза: Предоставить проект на рассмотрение экологической экспертизы

**ЗАКЛЮЧЕНИЕ:**

Земельный участок Строительство санитарного узла - общественной туалета  
ул. Торугарт от Бишкекской к-ны  
Муниципальное Управление Нарынского и Коммунистического к-нов.  
по экологическим условиям:  
а) пригоден для строительства: присоединен  
б) не пригоден (указать основания) \_\_\_\_\_

Настоящее заключение действительно с 12.06.2014 по 12.06.2016 г.

Начальник НТУООС: Калыбек уулу Болотбек Должность, подпись

Получил: А. Рустамов Ф.И.О. \_\_\_\_\_ Дата \_\_\_\_\_

13.06.2014 10:18 AM FAX

TRANSLATION

State Agency for Environment Protection and Forestry of the Kyrgyz Republic

16.06.2014

04-01-28/1343

Ministry of Transport and Communications

Naryn TA of SAEPF

With reference to your outgoing letter # 14-3/3310 dated 23.05.2014

The State agency for environment protection and forestry under the Government of the Kyrgyz Republic (SAEPF) having considered your letter # 14-3/3310 dated 23.05.2014 regarding the designed construction of the parking area with necessary infrastructure for purposes of traffic safety and reducing congestion of vehicles along the road before the customs post "Torugart" and the land acquisition opinion issued by the Naryn territorial administration of the SAEPF #108-в dated 12.06.2014, has no objections to designing construction of a public lavatory at km 530 of the Bishkek-Naryn-Torugart road.

However, it is necessary to:

- Provide to the Naryn territorial administration of the SAEPF the relative design documents for the designed parking area facilities for the state ecological expertise prior to the construction, as required by the legislation of the Kyrgyz Republic.

Sincerely,  
Deputy director

A. Rustamov

